

# churchfitters

## Tech. spec.

### Stage Plan

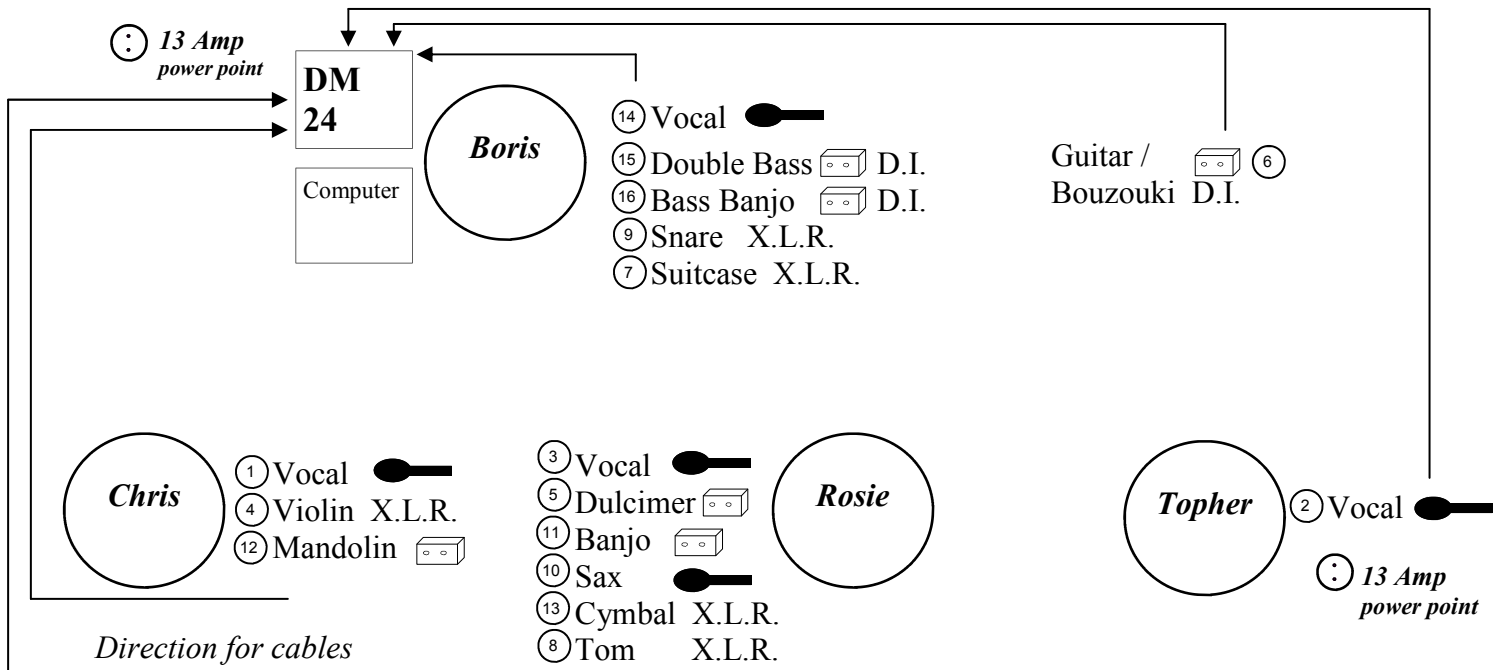

### Required Equipment

- EQ:** 1 stereo equalizer 2 x 31 band  
*Models:* Klark Technic DN-360, DN-27A or equivalent
- Microphones & DIs :** 4 SM58s  
6 active D.I.s
- Microphone stands :** 3 boom stands
- P.A. :** Active system **with Sub bass** adapted to the size of venue and to acoustic music
- Cables :** 18 X.L.R. / X.L.R. cables
- everything is patched to the Tascam DM 24 on stage
  - the DM 24 is patched via the EQ to the front desk to two channels ( no phantom power needed )
  - it is important that the P.A. speakers are not placed on the stage

### Churchfitters Equipment

- Tascam DM 24 mixing desk, for the Churchfitters use only
- computer
- ear-monitor system
- microphone for the sax
- all the instruments

Technical , P.A. contact : Boris LEBRET  
boris.lebret@wanadoo.fr

Band contact : Rosie SHORT  
rshort@free.fr  
00 33 (0)2 99668206